

Jain PVC Foot Valve®

A Real Pump Guard



Features & Benefits

Compact Design

Innovative design manufactured from high performance rigid PVC compound



Unique Design of Strainer

Unique design of strainer effectively screens trash and ensures minimum obstruction to flow.



Excellent and Long Life Seal

Positive shut off prevents leakage & avoids repeated priming of the pump.



Precise Weight for Rubber Cap

For Rubber seal precise weight given for quick seal

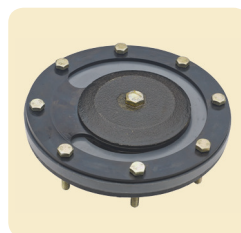

Jain PVC Foot Valve®

Additional Features:

- Excellent chemical and corrosion resistance
- Light weight, no extra weight on suction pipe.
- 'K' value (friction coefficient of the valve) less than 0.8 ensures low frictional loss.
- Energy savings up to 30%
- Available in sizes of 2½", 3.0" and 4.0" BSPT/NPT female threaded connections (65, 80 & 100 mm)

Application

Maintains water column in suction pipe of the pump

List of Spares

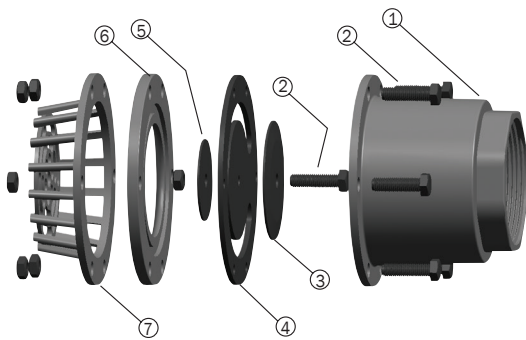

Sl.	Description	Material
1	Body	PVC
2	Nut & Bolt	Mild Steel
3	Weight	Cast Iron
4	Rubber Flap	Nitrile
5	Washer	Mild Steel
6	Flange	PVC
7	Strainer	Nylon

Dimensional Specification

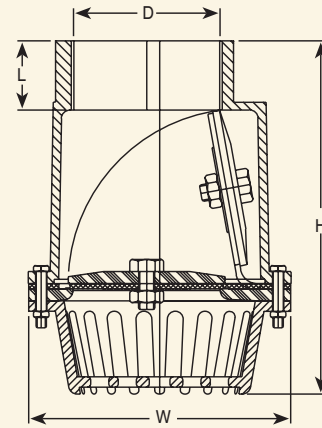

Size	D	W	H	L
inch	mm	mm	mm	mm
2½"	65.00	130.00	148.00	23.00
3"	80.00	153.00	185.00	23.00
4"	100.00	200.00	206.00	30.00

Ordering Specifications

JFV	XX	XXX
	Size, inch	Type of Connection
	212 - 2½"	BTF - BSPT female threaded
	300 - 3"	NPF - NPT female threaded
	400 - 4"	

Example: JFV212BTF - This code represents Jain PVC Foot Valves® of size 2½" with BSPT female threaded connection.

